

metal oxide power type leaded resistor

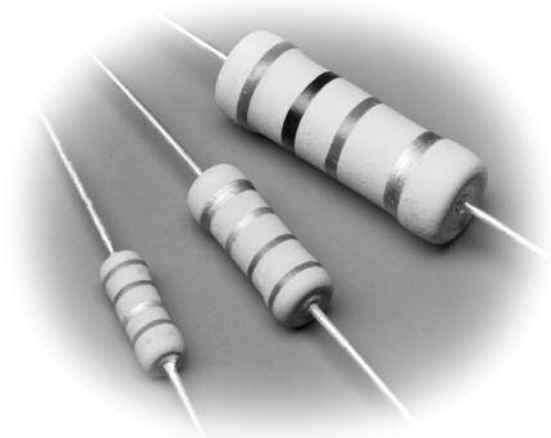

features

- Flameproof silicone coating equivalent to (UL94V0)
- Suitable for automatic machine insertion
- High reliability for performance
- Products with lead-free terminations meet EU RoHS and China RoHS requirements



dimensions and construction

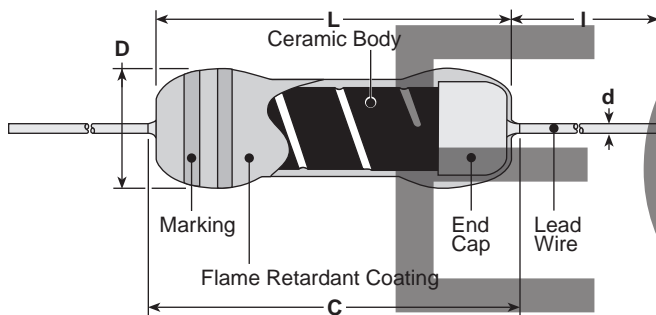

Type	Dimensions inches (mm)				
	L	C (max.)	D	d (nom.)	I*
MO1/2 MOX1/2	.354±.039 (9.0±1.0)	.437 (11.1)	.126±.02 (3.2±0.5)	.028 (0.7)	.945 Min. (24.0 Min.)
MO1 MOX1	.472±.039 (12.0±1.0)	.59 (15.0)	.157±.02 (4.0±0.5)		
MO2 MOX2	.610±.039 (15.5±1.0)	.709 (18.0)	.236±.039 (6.0±1.0)	.031 (0.8)	1.18±.118 (30.0±3.0)
MO3 MOX3	.965±.039 (24.5±1.0)	1.10 (28.0)	.354±.039 (9.0±1.0)		1.50±.118 (38.0±3.0)

* Lead length changes depending on taping and forming type.

ordering information

MO	1	C	T52	A	473	J
Type	Power Rating	Termination Material	Taping and Forming	Packaging	Nominal Resistance	Tolerance
MO MOX	1/2: 0.5W 1: 1W 2: 2W 3: 3W	C: SnCu	Axial: T52, T521, T631 Stand-off Axial: L52, L521, L631 (MO3/MOX3 bulk packaging only)	A: Ammo R: Reel	2 significant figures + 1 multiplier "R" indicates decimal on value <10Ω	G: ±2% J: ±5%

For further information on packaging, please refer to Appendix C.

metal oxide power type leaded resistor

resistors

applications and ratings

Part Designation	Power Rating @ 70°C	Minimum Dielectric Withstanding Voltage	T.C.R. (ppm/°C) Max.	Resistance Range E-24 (G±2%)	Resistance Range E-24 (J±5%)	Absolute Maximum Working Voltage	Absolute Maximum Overload Voltage	Operating Temperature Range
MO1/2	0.5W	400V	±200	10Ω - 47kΩ	10Ω - 47kΩ	$E = \sqrt{P \times R}$	400V	-55°C to +200°C
MO1	1.0W	500V					10Ω - 100kΩ	
MO2	2.0W			500V	10Ω - 150kΩ	500V		
MO3	3.0W	500V					5.1Ω - 9.1Ω	
MOX1/2	0.5W							
MOX1	1.0W							
MOX2	2.0W							
MOX3	3.0W							

environmental applications

Derating Curve

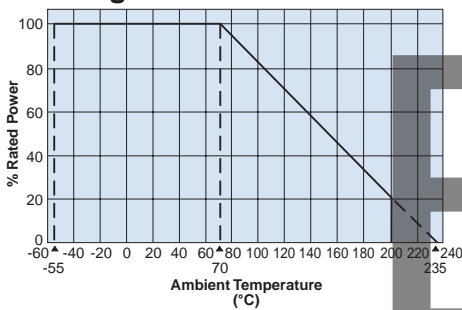

Surface Temperature Rise

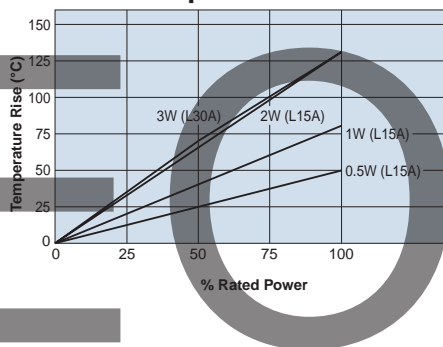

Load Life @ 70°C, 1000 Hr

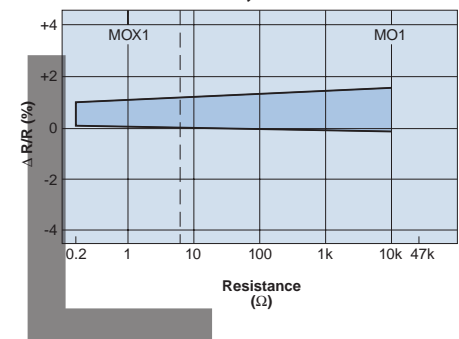

Performance Characteristics

Parameter	Requirement $\Delta R \pm(\% + 0.05\Omega)$		Test Method
	Limit	Typical	
Resistance	Within specified tolerance	—	Measuring points are at 10mm ±1mm from the end cap.
T.C.R.	Within specified T.C.R.	—	+25°C/+125°C
Overload (Short time)	±1%	±0.5%	Rated voltage x 2.5 or max. overload voltage for 5 seconds, whichever is lower
Resistance to Solder Heat	±1%	±0.5%	260°C ±5°C, 10 seconds ± 1 second
Terminal Strength	No lead-coming off and loose terminals	—	Twist 360°C, 5 times
Rapid Change of Temperature	±1%	±0.5%	-55°C (30 minutes), +155°C (30 minutes), 5 cycles
Moisture Resistance	±(5%+0.1Ω)	±2%	40°C ± 2°C, 90 - 95% RH, 1000 hours, 1.5 hr ON, 0.5 hr OFF cycle
Endurance at 70°C	±(5%+0.1Ω)	±2%	70°C ± 2°C, 1000 hours, 1.5 hr ON, 0.5 hr OFF cycle
Resistance to Solvent	No abnormality in appearance. Marking shall be easily legible	—	Ultrasonic washing with isopropyl alcohol for 2 minutes. Power: 0.3W/cm ³ , f: 28kHz, Temp: 35°C ±5°C
Flame Retardant	No evidence of flaming or self-flaming	—	Flame test: the test flame shall be applied and removed for each 15 seconds respectively to repeat the cycle 5 times. Overload flame retardant: power (AC) corresponding to 2, 4, 8, 16 and 32 times the power rating shall be applied for each 1 minute until disconnection occurs. However the applied voltage shall not exceed the value of 4 times of the maximum operating voltage