

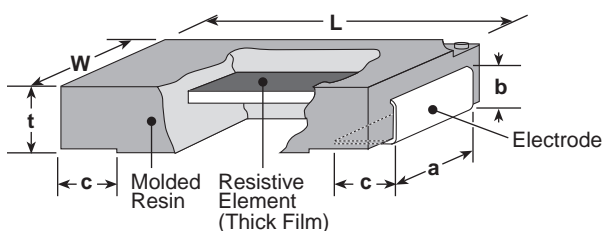

features

- Thick film resistor protected by liquid crystal polymer resin
- Excellent heat cycle characteristics
- Encapsulated with flame retardant resin molding. (UL94 V-0)
- High operating temperature range up to 180°C
- Products meet EU RoHS requirements. EU RoHS regulation is not intended for Pb-glass contained in electrode, resistor element and glass.
- AEC-Q200 Qualified

dimensions and construction



Size Code	Dimensions inches (mm)					
	L	W	t	a	b	c
SLR1 (2512)	.248±.012 (6.3±0.3)	.122±.008 (3.1±0.2)	.075±.008 (1.9±0.2)	.094±.008 (2.4±0.2)	.047±.008 (1.2±0.2)	.047±.012 (1.2±0.3)

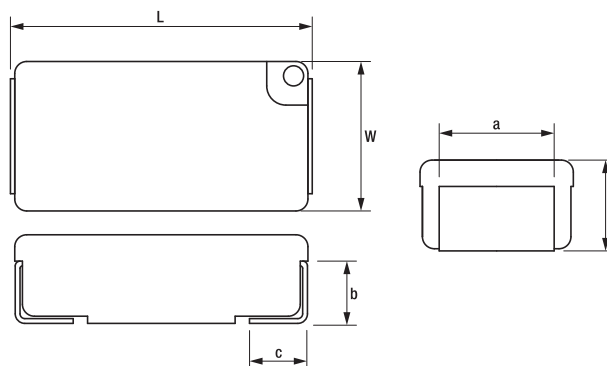

ordering information

SLR	1	T	TE	R301	F
Type	Power Rating	Terminal Surface Material	Packaging	Nominal Resistance	Resistance Tolerance
SLR	1: 1.0W	T: Sn	TE: 8mm Pitch embossed plastic TED: 8mm Pitch embossed plastic	D, F: 4 digits J: 3 digits	D: ±0.5% F: ±1% J: ±5%

Resistance Value (Ω)	3 Digits	Resistance Value (Ω)	4 Digits
0.33 ~ 0.91	R33 ~ R91	0.301 ~ 0.976	R301 ~ R976
1 ~ 9.1	1R0 ~ 9R1	1 ~ 9.76	R100 ~ 9R76

Contact us when you have control request for environmental hazardous material other than the substance specified by EU RoHS.

For further information on packaging please refer to Appendix A.

applications and ratings

Part Designation	Power Rating	Rated Ambient Temp.	Rated Terminal Part Temperature	Resistance Range (Ω)			T.C.R. (X10 ⁻⁶ /K)	Maximum Working Voltage	Maximum Overload Voltage	Operating Temp. Range
				D: ±0.5% E24, E96	F: ±1% E24, E96	J: ±5% E24				
SLR1	1W	70°C	90°C	301m - 1M	301m - 1M	330m - 1M	±100	200V	400V	-55°C to +180°C

Rated voltage = $\sqrt{\text{Power Rating} \times \text{Resistance Value}}$ or Max. working voltage, whichever is lower

If any questions should arise whether to use the "Rated Ambient Temperature" or the "Rated Terminal Part Temperature," please give priority to the "Rated Terminal Part Temperature." Prior to use and for more details refer to "Introduction of the derating curves on the terminal part temperature" in the beginning of the catalog.

environmental applications

Derating Curve

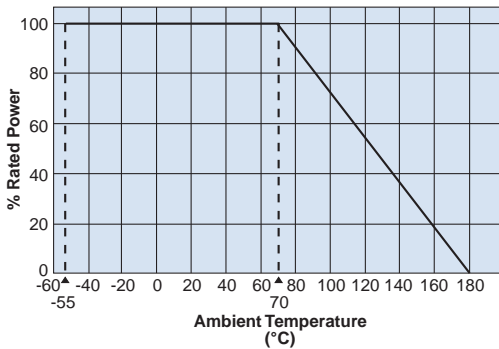

For resistors operated at an ambient temperature of 70°C or above, a power rating shall be derated in accordance with the above derating curve.

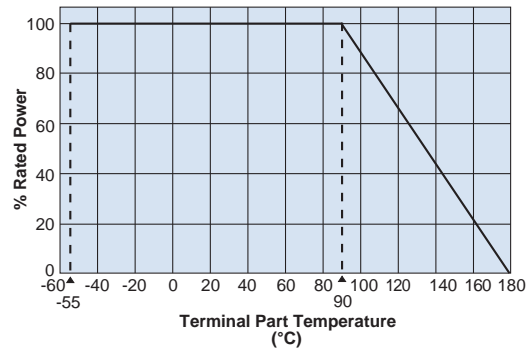

For resistors operated at a terminal part temperature of described for each size or above, a power rating shall be derated in accordance with the derating curve. Please refer to "Introduction of the derating curve based on the terminal part temperature" in the beginning of our catalog before use.

Temperature Rise

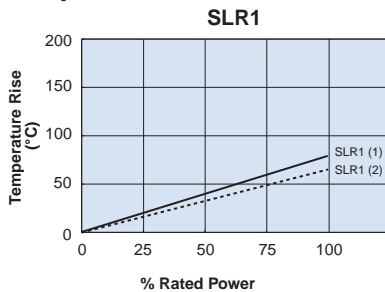

Regarding the temperature rise, the value of the temperature varies per conditions and board for use since the temperature is measured under our measuring conditions.

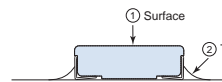

Measurement condition
Room temperature: 25°C
PCB: FR-4t = 1.6mm
Cu foil thickness: 35μm

One-Pulse Limiting Electric Power

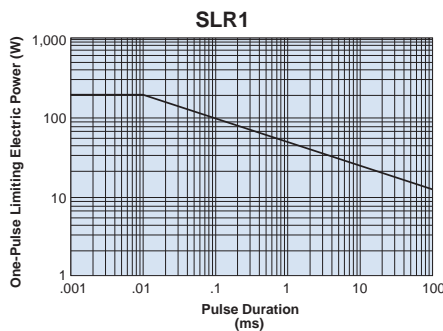

The maximum applicable voltage is equal to the max. overload voltage.

Please ask us about the resistance characteristic of continuous applied pulse.

The pulse endurance values are not assured values, so be sure to check the products on actual equipment when you use them.

Performance Characteristics

Parameter	Requirement Δ R ±%		Test Method
	Limit	Typical	
Resistance	Within specified tolerance	—	25°C
T.C.R.	Within specified T.C.R.	—	+25°C/+125°C
Overload (Short time)	±1%	±0.1%	Rated power times 5 for 5 seconds
Resistance to Solder Heat	±1%	±0.3%	260°C ± 5°C, 10 ± 1 second
Rapid Change of Temperature	±1%	±0.4%	-55°C (30 minutes), +155°C (30 minutes), 1000 cycles
Moisture Resistance	±2%	±0.2%	40°C ± 2°C, 90%~95%RH, 1000 hours, 1.5 hr ON, 0.5 hr OFF cycle
Endurance at 70°C	±2%	±0.2%	70°C ± 2°C, 1000 hours, 1.5 hr ON, 0.5 hr OFF cycle

Specifications given herein may be changed at any time without prior notice. Please confirm technical specifications before you order and/or use.

10/28/20